

# JMS-10-MDT

Mobile Diesel Track Dust Collector

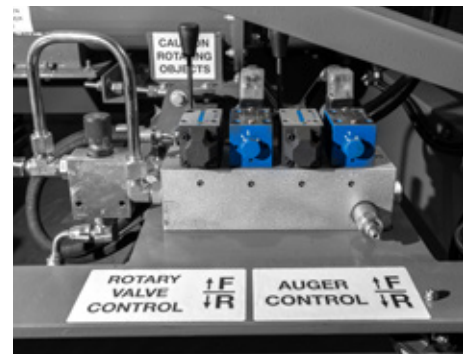



# Grydale

Original Equipment Manufacturer (OEM) of fixed and mobile dust collection equipment

## Health and Safety. Driving Demand for Effective Dust Control Solutions

Market demand for dust control solutions is increasing globally, with health and safety experts focused on increasing dust control regulations to protect workers from potentially hazardous consequences.

Disease-causing dusts are found in a large number of industries. They include but are not limited to asbestos, crystalline silica, hard metals, aluminum, bagasse, cotton, hay, straw and grains. Dust is created and can be inhaled when cutting, sanding, drilling or grinding, for example during demolition, construction or earthworks.

The risk of dust-related diseases increases with exposure levels. Workplace health and safety legislation now places strict requirements for the management of dust through Permissible Exposure Limits (PEL) and Workplace Exposure Limits (WEL). Regulations are periodically reviewed and updated to take into account current scientific evidence linking exposure to disease.

Silicosis is the most common occupational lung disease worldwide, and often referred to as the 'modern day asbestos'.

## JMS M-Series. Mobile Dust Collectors

Our internationally-patented JMS M-Series dust collectors are complete dust collection systems that feature a centrifugal exhaust fan, dirty air intake, patented drop-out box, high efficiency filters, reverse pulse filter cleaning system, dust discharge system, clean air exhaust and fan silencer. All components are mounted on a single mobile base to create 12,000CFM-125,000CFM (6m<sup>3</sup>/s to 60m<sup>3</sup>/s) of air flow.

Grydale JMS M-Series mobile dust collectors feature proprietary technology that sets the units apart as pioneering dust collection solutions.

The JMS M-Series is a comprehensive range of mobile dust collectors. Units are available powered by diesel, electric or hybrid systems. A full range of mobility options are available including the internationally patented track-mounted units, hydraulic stepping systems, drag skids, trailer-mounted and castor-wheel (tow-able) units.

Mobility combined with a compact integrated design provides significant advantages on construction sites.

## Industries We Serve



MINING



TUNNELLING



ABRASIVE  
BLASTING



BULK STORAGE  
HANDLING



SOURCE  
EXTRACTION



CIVIL  
CONSTRUCTION

Grydale mobile dust collection units are being used to manage dust and fume exposures within a wide range of industries.



# JMS-10-MDT

Internationally patented track-mounted mobile dust collector

## Overview

The JMS-10-MDT (Mobile, Diesel, Track) is a complete dust collection system mounted on a compact, track base. It features a centrifugal exhaust fan to create 20,000CFM @ 12iwg (10m<sup>3</sup>/s @ -3kPa).

## Mobility

Grydale holds international patents for manufacturing the only self-propelled dust collector on tracks on the market.

The Grydale JMS-10-MDT is mounted on a 10T track undercarriage to offer full mobility and better control with variable speeds between 1-3mph (2-4kph), to increase the speed and efficiency of operations.

Track units are able to move and operate alongside excavation equipment to provide effective dust collection at source where mobility and maneuverability are key.

## Remote Control Operation

The JMS-10-MDT is driven using remote control. Corded control will also be provided as a fail-safe.

## Diesel Power

The JMS-10-MDT uses a T4F Kohler diesel engine to power the hydraulic pumps which drive the centrifugal exhaust fan, tracks, auger, rotary valve discharge system and screw compressor.

## Air Intakes

The JMS-10-MDT features flexible intake options which means that it can be used as a general ventilation machine or for source extraction. Flexible couplings allow the dirty air intake to connect effectively to ducting on uneven surfaces.

- The single 39.4" (1000mm) air intake is best suited when there are large dust volumes.
- Additional 3 x 20" (508)mm side air intakes can provide spot dust extraction from multiple sources.

## Filters

18 high-efficiency filter cartridges provide filtration of both dust and diesel particulates. Baffle plates distribute air throughout the dust collector ensuring an even wear of filters.

## Filtration Efficiency

Independent, certified air flow performance and filtration testing has been conducted both above and below ground as part of rigorous performance verification and certification processes and shows a collection efficiency of 99.99% at 0.067 micron.

## Filter Maintenance

The filters can be easily accessed through the three filter access doors to allow efficient filter maintenance to maximize machine uptimes.

Changing the filters at the optimum time ensures the dust collector does not draw more power than required to maintain air flows.

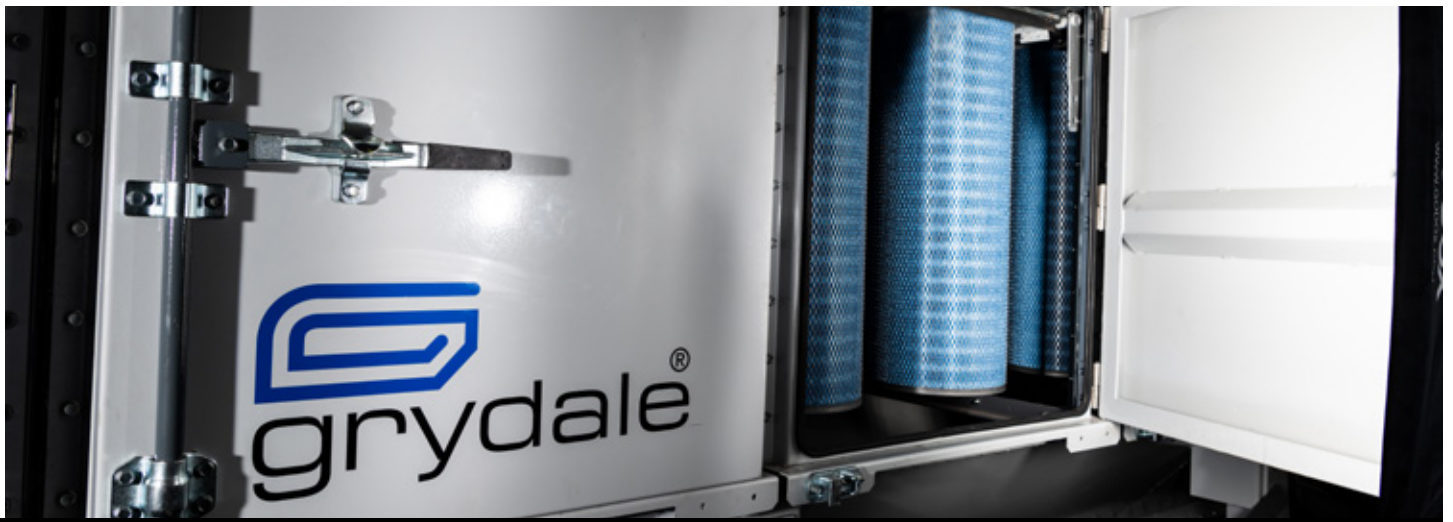

# Key Features

Certified air flow performance and filtration

## Reverse Pulse Cleaning System

The JMS-10-MDT features an on-board compressor, used for the reverse pulse filter cleaning system.

Jet tubes direct air inside the filters which blasts air from the inside of each filter, effectively removing dust build-up and preventing the filters from clogging. An adjustable timer allows the pressure and frequency of pulse cleaning to be set to the application and dust loading. This reduces the number of filter changes required.

**Configuration option:** A plant air attachment kit can also be fitted to the unit if there is air supply on-site.

## Centrifugal Fan

Centrifugal fans offer superior energy efficiency and enhanced durability, allowing them to operate in even the most corrosive environment.

The standard configuration for the JMS-10-MDT features a 100hp (75kW) centrifugal fan to provide 20,000CFM at -12iwg (10m<sup>3</sup>/s @ -3kPa) using one motor and one impeller to develop system pressure.

## Fan Silencer

Exhausted air passes through curved silencers to reduce noise pollution. Units can be supplied with a square-to-round attachment allowing a vent bag to be attached to the exhaust side if required.

**Configuration option:** Custom exhaust silencers can be designed and manufactured to meet site acoustic requirements.

## Dust Discharge System

The standard configuration for the JMS-10-MDT includes a hydraulic reversible front-facing auger and stainless steel rotary valve dust discharge system. The auger discharges dust particles to the site floor.

The use of hydraulics to power the augers and rotary valves maximizes their efficiency while the ability to reverse the augers and force material through clean-out hatches is key to increasing uptime in the event of product build up in the hopper and auger. This reduces the maintenance effort and the requirement to have Low Voltage (LV) and High Voltage (HV) electricians servicing a mechanical component.

**Configuration options:** A front-or-side-facing incline auger can be configured to discharge dust to 1T bulker bags if required.

## Programmable Logic Computer (PLC) with HMI Interface

A simple one-button start-up/shut-down sequence starts and stops all critical components in a programmed order which increases the efficiency of the unit and provides additional safety for workers.

A 7" button dashboard display facilitates ease of operation. On-screen instructions and warnings display error codes which provide a powerful diagnostic tool to support service and maintenance staff.

**Configuration option:** 12" touchscreen display.



# Key Features

Sophisticated instrumentation combined with CANbus technology

## CANbus System

The CANbus system enhances the speed, flexibility, and reliability in communication along with supporting effective troubleshooting and maintenance from off-site. The system retains key alarm logs so that performance and troubleshooting can be undertaken as required.

Key instruments that use the CANbus system include:

### Real-Time Emissions Monitoring

Real-time particle detectors examine emissions coming out of the clean air exhaust and can be tuned to meet the requirements of any given site. The unit can be programmed to alarm when levels are being approached and exceeded.

### Static and Differential Pressure Gauges

The static pressure monitor alerts the operator if it is necessary to turn the system volume up due to a long duct run or if there's a blockage in the ducting. The differential pressure monitor alerts the operator if filters are blocked or if there are higher than normal dust loads.

### Fuel Level Indicator Lights

Fuel level indicator lights alert the operator to remaining fuel levels.

### Proximity Sensors (Optional)

When fitted, proximity sensors will alert the operator when any object becomes close to the unit when tracking.

## Central Automatic Greasing System

Grease banks are fitted as standard to all units.

**Configuration Option:** An automatic greasing system can be fitted. This ensures all bearings are maintained at correct intervals, extending operational life and reducing the time required at service periods.

## Safety Features

JMS M-Series dust collectors offer a number of features that focus on maximizing the health and safety of workers along with providing a safe working environment by controlling dust and fumes. Key safety features on the JMS-10-MDT include:

### Emergency Stop Lanyard System

One emergency stop button is located on the unit plus a safety lanyard system runs around the perimeter of the unit enabling anyone to immediately halt the machine with immediate effect.

### Split Starter and Battery Isolators

Split starter and battery isolators allow use of service lights when the engine is off or being maintained and also permit full machine diagnostics with no risk to service and maintenance staff.

### Operation and Maintenance Lights

Operational and maintenance lights have been fitted in key locations on the unit giving operators and maintenance workers clear visibility of components and/or to illuminate working spaces.

### Fire Suppression System (Optional)

To be compliant with current underground regulations, a fire suppression system can be added to surround the diesel engine if required.

# Technical Specification

## JMS-10-MDT

### Overview

Air Volume	20,000CFM (10m³/s)
Power	Kohler KDI 3404 105kW T4 Diesel
Fuel Tank	58 gal (220L) Diesel Fuel Tank 12 gal (45L) Adblue Fuel Tank
Mobility	Track Mounted with Remote Control Operation
Fabrication	0.12" x 0.20" Mild Steel International Two Pack Paint
Air Intake Ø	1 x 23.6" (1000mm) Ø plus 2 x 13.8" (350mm) Ø

### Filter Technical Data

Number of High Efficiency Filters	18
Filter Cleaning Efficiency	99.99% at 0.067 micron
Total Filter Surface Area	5425ft² (504m²)
Filter Temperature Limit	179.6°F (82°C)
Method of Changing Filters	Via 3 Filter Doors
Estimate Filter Change Time	Two technicians x 2hrs
Pre-Cleaning of Air Prior to Hitting Filters	No

### Centrifugal Fan

Maximum Pressure Drop Across Filters	-12iwg (-3kPa)*
Variable Air Flow Control	Yes
Fan Silencer	Yes Option: to supply square to round attachment to allow vent bag to be attached to exhaust

### Reverse Pulse Cleaning System

Reverse Pulse Cleaning Solenoids	6
On-board Compressor	Yes – 60 CFM Compressor
Plant Air Attachment	Optional Extra
Adjustable Pressure & Frequency Rate	Yes
Auto Drains	Yes

### Discharge System

Hydraulic Reversible Auger	1
Main Screw Conveyor Auger	1 – Front Discharge
Incline Screw Conveyor Auger	Optional Upgrade: Front or Side Incline Discharge
Stainless Steel Rotary Valves	1



### Instrumentation

PLC	Yes
HMI	7" Touch Button Display Option: 12" Touchscreen Display
Control System	CANBus
Static & Differential Pressure Gauges	Yes
Emissions Monitoring Probe	Yes – 24V
Operational Lights & Alarms	Yes
Work Safety Lights	6 x 24VDC Lights
Fuel Level Indicator Lights	Yes
Velocity Probe	Optional Upgrade
Proximity Sensors	Optional Upgrade
Auto Greasing System	Optional Upgrade

### Safety Features

Emergency Stop	1 E-Stop
Emergency Stop Lanyard System	Yes
Amber Rotating Beacons	2
Split Battery and Starter Isolator	Yes
Fire Suppression System	Optional Upgrade

\* Alternative centrifugal fans can be utilized to optimize air volume and pressure to suit site conditions and specific applications.

# Technical Specification

## JMS-10-MDT

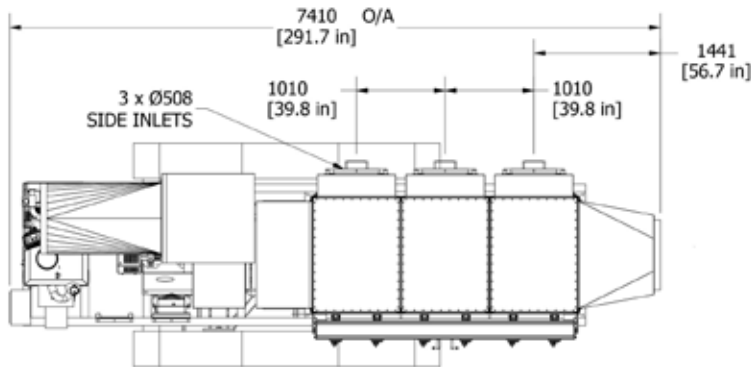

TOP VIEW

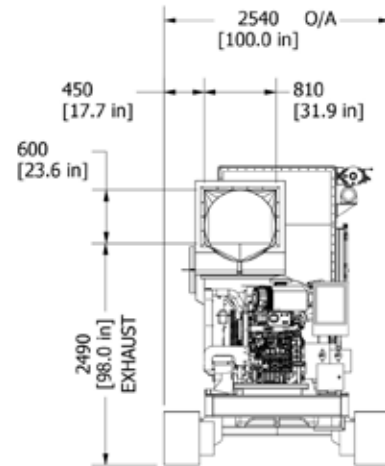

LEFT VIEW

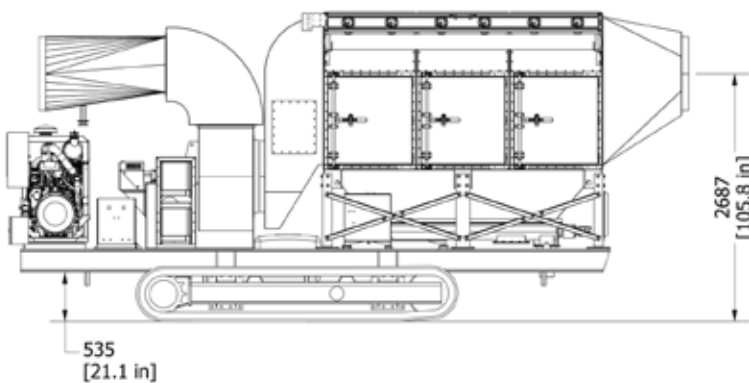

FRONT VIEW

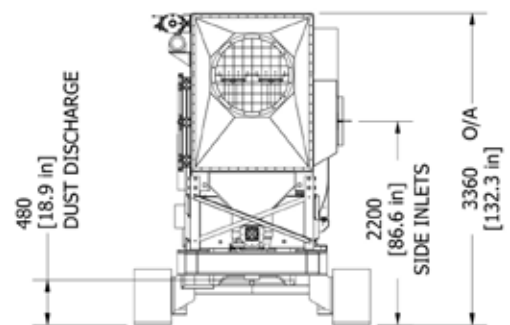

RIGHT VIEW

### Key Dimensions

Maximum Height	132.3" (3,360mm)
Maximum Width	100" (2,540mm)
Maximum Length	291.7" (7,410mm)
Mass	18T

### Other models in the JMS 10 M-Series

- **JMS-10-MDS**- mobile, diesel, skid dust collector
- **JMS-10-MES**- mobile, electric, skid dust collector
- **JMS-10-MEC-XP**- mobile, electric, castor-wheel dust collector

### Grydale. Experts in Dust Control

Our team has over 15 years of experience designing and manufacturing industrial dust collection and extraction solutions. We focus on adding value through a total service offering, providing ventilation design, manufacturing, implementation, ongoing project management and on-site maintenance and technical support.

Contact us for more information:

[info@grydaleusa.com](mailto:info@grydaleusa.com)



**Grydale USA LLC**  
**Part of the Grydale Group Pty Ltd**

14900 Interurban Avenue South,  
Ste. 271 PMB #88, Seattle WA 98158  
+1 1888 479 3153  
info@grydaleusa.com  
www.grydaleusa.com  
UBI: 604 725 936

**Grydale Canada Ltd**  
**Part of the Grydale Group Pty Ltd**

4211 Prospect Road,  
North Vancouver, BC, V7N 3L6  
+1 (778) 897 2229  
info@grydalecanada.com  
www.grydalecanada.com  
Company Number: 126402-2